

### Introduction

A common application in today's fast paced semiconductor industry is measuring high frequencies in the RF/Microwave region (GHz). RF/Microwave measurements enable engineers to characterize both the linear and nonlinear behavior of devices, providing critical information such as the cutoff frequency of a filter and amplifier power output. RF/Microwave measurement applications can be difficult without the proper measurement equipment and further complicated if proper techniques are not used. The Micromanipulator Company has responded to the demands of RF/Microwave probing, offering a complete line of unparalleled RF/Microwave probing stations and accessories designed to meet the needs of the probing professional.

Micromanipulator invented analytical probing more than 40 years ago. Since then, Micromanipulator has lead the industry developing a wide range of knowledge and expertise. We have designed complete RF/Microwave probing systems that are easy to use and capable of obtaining repeatable and consistent measurement data. For example, our RF/Microwave probing systems have been designed to painlessly interface to Network Analyzers. Of equal importance, our probe stations have been designed to be extremely stable, reducing vibrations while increasing overall probe and cable stability. During actual measurements and calibrations, stability of the probe station, probe and cable is very important. What's more, Micromanipulator probe stations allow both low level DC and high frequency AC measurements on the same probe station.

In addition, Micromanipulator has partnered with the industry leader in RF/Microwave probes, GGB Industries. We offer the complete GGB Picoprobes line of RF/Microwave passive probes. The durable Picoprobes enhance the unmatched RF/Microwave probing capabilities of Micromanipulator probe stations by adding probes with extremely low insertion loss, high return loss and excellent measurement repeatability.

GGB's Picoprobes offer the widest range of pitch (probe spacing) configurations available and include individually spring loaded probe tips to further reduce calibration and probe contact issues.

### What to Consider

When considering a RF/Microwave probing system, consider the following elements:

- Probe station with a calibration substrate chuck.
- Manipulators and probe head links.
- RF/Microwave probes.
- Calibration substrate.
- Cables.

### Station and Calibration Substrate Chuck

There are three options available from Micromanipulator when considering a probe station for RF/Microwave probing; manual, motorized and semi-automatic. Choosing between these stations is a matter of personal choice, budget and application. Most of Micromanipulator probe stations have an available RF Option. All our probe stations have open designs that facilitate RF/Microwave cable routing and overall setup flexibility.

Micromanipulator recommends the model 4460 for 6"/8" (150/200mm) semi-automatic applications and the 4060 for manual applications. The 4460 and 4060 RF Option probe stations are recommended because of their rock solid four point platen support/lifts that mechanically isolate vibration and their large area platen that accommodates a variety of probing setups, cabling and large RF/Microwave manipulators. In addition, the probe stations are available with a wide variety of microscopes, including the very popular Thales Optem's A-Zoom and USMCO's Tilthead ergonomic microscope. The 4460/4060 RF Option probe stations are available with Z chuck mount and drives, a Micromanipulator pioneered technology. Micromanipulator has developed the technology to smoothly raise and lower the probe station's platen for probe touchdown and separation. Professionals appreciate the ability to see the DUT while at the same time protecting expensive RF/Microwave probes. In contrast, when the station chuck is allowed to move in Z, sample focus is lost and probe damage is far more likely because the distance between the probes and the point of contact is not visible.

The model 4460/4060 probe stations, when configured for high frequency measurements, are equipped with calibration substrate compatible chucks. These chucks are designed with a fixture placed on the side of



1555 Forrest Way  
Carson City, NV 89706  
info@micromanipulator.com  
www.micromanipulator.com  
Tel: 775-882-2400  
Tel: 800-654-5659  
Fax: 775-882-7694  
Made in the USA

A1012911 rev 5 © 10/02

Specifications subject to change without notice.

the chuck body that is designed to simultaneously hold a DUT and calibration substrate during testing. The substrate fixture does not restrict stage movement and increases testing efficiency because calibrations can be conducted without removal of the DUT. For more information about the model 4460/4060 RF Option probe stations, refer to the 4460/4060 features and specifications brochure.

**"Triple" Mount**

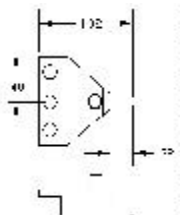

Style 'C'

**"Double" Mount**

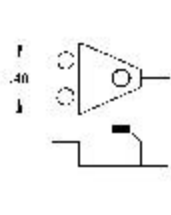

Style 'T'

*Link Arm Mounting Styles*

When ordering your calibration substrate chuck, reference the following: for an ambient 6" (150mm) or 8" (200mm) calibration substrate chuck order a standard chuck plus part number CTAB-8000 and for an ambient 12" (300mm) calibration substrate chuck, order CATB-9000 plus a standard ambient chuck.

**Manipulators and Probe Head Links**

The RF/Microwave manipulators and probe head links supplied by Micromanipulator are another key element of an optimal RF/Microwave setup. Shown to the right is the model WAVE 100/200 manipulator equipped with a probe head link arm. The WAVE 100/200 manipulators feature rectilinear XYZ axis controls that are easily accessible from the

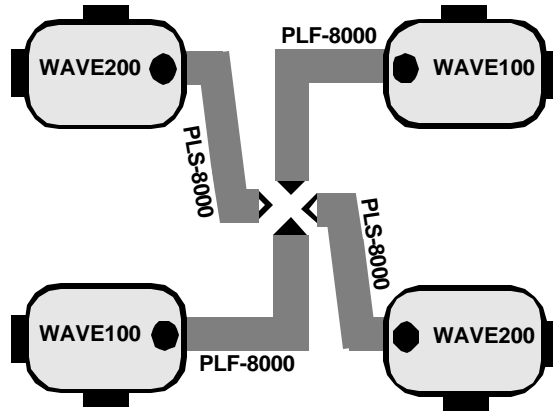

*Manipulator/Link Arm Possibilities*

top of the probe station. They are designed to probe pad sizes of 2 microns and above and have a large footprint that helps reduce probe vibration. In addition, the manipulators come standard with controls that provide 4° of probe planarization and theta adjustment. Precise tip planarization and theta adjustments are critical to RF/Microwave applications to maintain probe contact with non-planar structures and precise tip placement.

Reference the following part numbers when ordering manipulators:

**Left Handed Manipulator**

- WAVE100/MT; magnetic base (requires a magnetic platen)
- WAVE100/MAV; magnetic assisted vacuum base
- WAVE100/VM; vacuum base
- Wave 100/ML; mechanical lock (requires station with RF option)

**Right Handed Manipulator**

- WAVE200/MT; magnetic base (requires a magnetic platen)
- WAVE200/MAV; magnetic assisted vacuum base
- WAVE200/VM; vacuum base
- WAVE200/ML; mechanical lock (requires station with RF option)

**Link Arms**

Order **PLS-8000** for straight link arms and **PLF-8000** for right angle link arms and identify station model for proper mounting.

To allow the use of four probes, you will need to purchase two straight

and two 90° probe head links. If your network analyzer is equipped with one test set (two ports), you will require only two manipulators (one left and one right) and two link arms. The diagram above shows the different link arm and manipulator possibilities. Choose the configuration that best meets your needs.

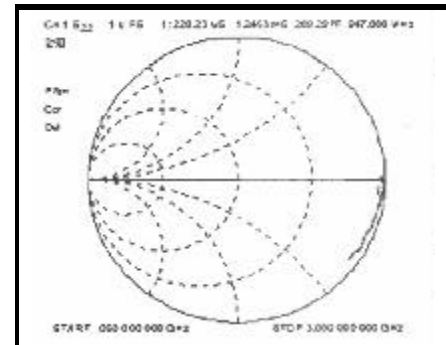

*Smith Chart showing open calibration*

**The Probes**

Micromanipulator offers the industry leading GGB Industries' *Picoprobes* RF/Microwave probes. They come standard with massive mounts to reduce vibration, extremely low

*Model WAVE100/VM manipulator*

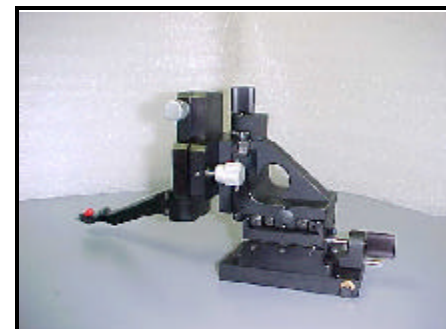

insertion loss values and outstanding measurement repeatability and return loss. Picoprobes feature Beryllium-Copper (BeCu) probe tips that are individually spring loaded to provide consistent and repeatable DUT and calibration substrate contact, even when probing non-planar surfaces. It is common to have DUT structures that are not in the same plain.

Picoprobes are available with almost any pitch and footprint configuration and use a patented coaxial design that further reduces cross talk and other sources of RF/Microwave measurement error. In addition, professionals will appreciate being able to view the probe tips when touching down. Some industry probes make probe tip viewing difficult, if not impossible, increasing the possibility of costly probe damage.



*Manipulator/Link Arm Possibilities*

When ordering your probes, you will need to specify your frequency range, tip configuration (ground signal ground (GSG), ground signal (GS), or signal ground (SG) and your desired pitch. For example, the part number 67A-GSG-250-MM denotes a model 67A Picoprobe with a ground, signal, ground configuration and a 250 micron pitch. (Note: the probe is configured from right to left, when the probe tips are facing you). For optimum performance, it is recommended that pitch spacing be kept as small as possible. Refer to the Picoprobes data sheets for more information.

## The Calibration Substrate

Calibration substrates enable the user to calibrate the complete RF/Microwave system (network analyzer + cabling + probes) to a known NIST standard. Micromanipulator offers GGB Industries complete line of calibration substrates. Each GGB Industries calibration substrate comes complete with extremely precise elements. Devices on the calibration substrates represent opens, shorts, matched loads and throughs. When used properly, the devices insure accurate on-wafer RF/Microwave test results.

The advantages of the GGB Industries calibration substrate offering, when used with a Micromanipulator RF/Microwave Probe Station include:

- Support of precise SOLT (Short, Open, Load, Through), LRM (Line, Reflect, Match) and LRL (Line, Reflect, Line) calibrations.
- Convenient alignment of open, short, matched load and through devices.
- Support of probe pitch ranges from 30 to 1,250 microns.
- Suitable for frequency ranges from DC to 220GHz.
- Support of GS, SG and GSG footprint configurations.

### How to Order your Calibration Substrate

When ordering a calibration substrate, consider the following:

- The footprint and pitch required by your application.
- The calibration type that is required (i.e., SLT, LRM, LRL, TRM).

The calibration substrates that are available are listed below:

Part Number	Foot print	Rec. Pitch (mm)	Pitch Range (mm)	Supported Calibrations
PP-CS5	GSG	75-250	75 - 250	SOLT, TRL, TRM, LRM, LRL
PP-CS8	GS,SG	50-250	50 - 300	SOLT, TRM, LRM
PP-CS9	GSG	250-600	150 - 600	SOLT, TRM, LRM, LRL
PP-CS10	GSG	600-250	225 - 1250	SOLT, TRM, LRM
PP-CS11	GS,SG	600-1250	175 - 1250	SOLT, TRM, LRM
PP-CS14	GS,SG	250-600	150 - 600	SOLT, TRM, LRM
PP-CS15	GSG	40-125 (SOLT)	40 - 125	SOLT, TRL, TRM, LRM, LRL
		30-125 (TRL, LRL)		
PP-CS16	GSG	60-175 (SOLT)	60 - 175	SOLT, TRL, TRM

Note: TRL and LRL calibrations are equivalent calibration procedures. TRM and LRM are also equivalent calibrations.

### Calibration Kit Files

Micromanipulator provides pre-made calibration kit files on a disk when a calibration substrate is purchased. These files make it easier for the end user to get the calibration coefficient data into the network analyzer instead of having to type the values into the machine manually. A unique file (or "cal kit" on disk) is made for each probe pitch. There is no additional charge for this cal kit file.

### There are several probe choices available:

Model	Frequency Range	Insertion Loss	Return Loss	Repeatability
40A	DC to 40GHz	< 0.8db	> 18db	-50db
50A	DC to 50GHz	< 1.0db	> 18db	-80db
67A	DC to 67GHz	< 1.1db	> 14db	-50db
110	DC to 110GHz	< 1.5db	15db	-50db
120	75GHz to 120GHz	Max of 1.75db	Max of 15db	-50db

Specials can be accommodated and other probes are available. Contact Micromanipulator for more details.

## Cables

Cables used in a RF/Microwave setup are frequency dependent. Low loss semi-rigid and flexible coaxial cables will allow measurements up to 110GHz, depending on the connectors supplied with the cable. For frequencies above 110GHz, waveguide cables are the cables of choice.

Cables are available from a variety of sources and are equipped with connectors appropriate for the frequency range that will be measured. In selecting the right cable, however, one should consider the overall length of the cable. A cable that is too short will not sufficiently interface to the probe station and probes, while a cable that is too long will degrade performance because of introduced phase shifts and signal loss between the input and output of the analyzer. While network analyzers can compensate for these inaccuracies, the dynamic range (directivity) of analyzers degrades with cable length. Micromanipulator therefore recommends and offers the following low loss, phase stable, semi-rigid coaxial cables equipped with the appropriate connectors:

<b>Cable</b>	<b>Length (in)</b>	<b>Connector At Test Set</b>	<b>Connector At Probe End</b>	<b>Bandwidth</b>
PP2.4FM-36	36	2.4mm, f	2.4mm, m	DC-50GHz
PPKFM-36	36	2.92mm, f	2.92mm, m	DC-40GHz
PPVFM-36	36	1.85mm, f	1.85mm, m	DC-67GHz
PP2.4MM-48	48	2.4mm, m	2.4mm, m	DC-50GHz
PPKFM-48	48	2.92mm, f	2.92mm, m	DC-40GHz
PPVFM-48	48	1.85mm, f	1.85mm, m	DC-67GHz

Test Sets incorporating female 3.5mm connectors can use male 2.92mm connectors to connect from the probe head to the test set. Examples of 3.5mm test sets are the HP8414B, HP8515A and the HP85110A

Other cables with different bandwidths and connectors are available. Special lengths can also be accommodated. When ordering cables, specify the length, your frequency range and the connector required for the S-Parameter test set that will be used. Test sets may not support the frequency range supported by the associated cable and connector, refer to your network analyzer/test set specifications for additional information.

### Sample RF/Microwave Configuration

The configuration below shows a sample Micromanipulator RF/Microwave configuration for a system equipped to probe 6" wafers from DC to 50GHz, with a manual test station and 1 test set (i.e., two ports).

### Sample Configuration

<b>Part Number</b>	<b>Description</b>
<b>4060-FS6-VO-1-A</b>	Manual 4060 probe station, 6", manual 2"x2"x4" microscope drive, no chuck
<b>RF-4060</b>	RF Option
<b>USMC-REM-V1-TH</b>	USMCO scope, ergonomic <i>tilthead</i> , remote illuminator control, 10x eyepieces, 2x, 10x and 20x objectives
<b>CHK6000-6C</b>	Thermal, coax 6" chuck
<b>CTAB-8000</b>	Chuck calibration tabs
<b>WAVE100/VM</b>	Vacuum base manipulator, left handed, 40 TPI
<b>WAVE200/VM</b>	Vacuum base manipulator, right handed, 40 TPI
<b>PLS-8000</b> (order 2)	Probe link, 4000/8000 stations, straight, double/triple mounting (one for each manipulator required)
<b>PP50ASSPPMM</b> (order 2)	Model 50A GGB Picoprobes, DC-50GHz; Specify ground signal ground and 150µm pitch
<b>CS-5</b>	Calibration substrate GSG footprint compatible, 75-250um pitch range, SOLT,TRL,TRM,LRL
<b>PP2.4MM-48</b> (order 2)	Low loss phase stable cable, 2.4mm, male to male, DC-50GHz, 48" length (one for each probe required)

#### Additional products/options available

In addition to the products discussed in this Product Guide, Micromanipulator offers the following products:

- Active probes for DC switching and low frequency circuit probing.
- Passive single tip and GS configuration probes for measurements from DC to 5GHz.
- 8800-DOWNSTOP, designed to prevent damage to costly RF/Microwave probes.
- High frequency probe cards designed to increase testing throughput.

For information about these products, or any other leading edge solution for your applications, contact Micromanipulator Company.